

CURRENT SHARE -GNT200 SERIES

This application note will provide schematic and brief instructions on implementing current sharing on S.L. POWER ELECTRONICS GNT200 series of power converters using the “droop” share method, externally.

This method also known as ‘voltage droop’ or ‘slope programming’ allows the paralleling of two or more converters, forcing each to share approximately equal output currents into a common load. As the name implies, this technique will cause the output voltage of each power supply to “droop” to nearly equal potential (typically $\pm 1\%$) by injecting control signals into the feedback loops of the supplies.

As depicted in the block diagram below, this control can be handled, inexpensively, by inserting a PCB assembly between the power supplies and the load.

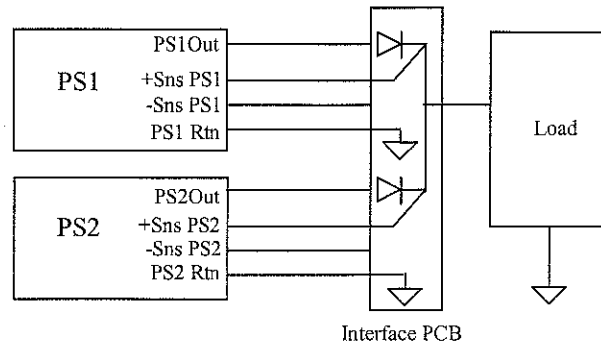

Block Diagram

Voltage sensing occurs at the load via ‘remote sense’ line placed after the OR-ing diode(s) (+Sns) and before the shunts (-Sns) as the currents through each converter are monitored and translated to a control voltage for their respective feedback loop. Placement of the current sensing shunts in the ‘return’ lines reduces the affect of common mode noise interjections into the feedback control.

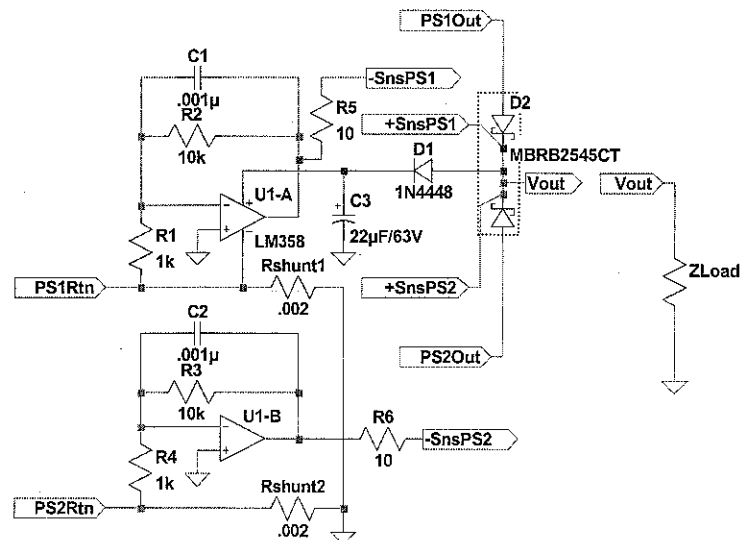

Current Share Schematic