

MINT1065 Series Overvoltage Protection Theory of Operation

The main circuit used to monitor the output and trigger the overvoltage protection is shown in Fig. 1. The trip voltage is determined by Zener ZS1 and optocoupler IC2-A. Upon an overvoltage condition, the optocoupler IC2-A turns on and, interacting with the bias supply circuit depicted in Fig. 2, raises the voltage on pin 1 of the control IC (UP1) above 7.2V, thereby latching off UP1. This in effect turns off the DC output of the power supply. The power supply is reset by cycling the AC input (removing Vcc to UP1).

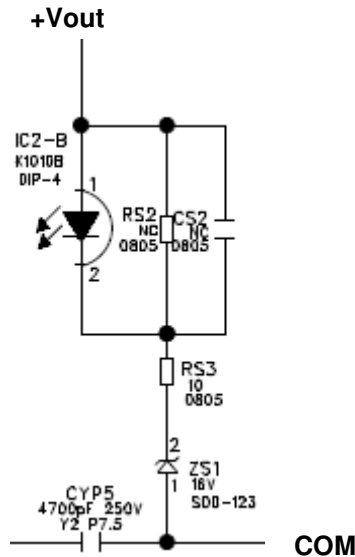

Fig. 1 – OVP circuit

The overvoltage protection circuit is independent of the regulation feedback circuit, which utilizes optocoupler IC1-A, and the feedback pin (pin 2) of the main control IC (UP1) to perform its function.

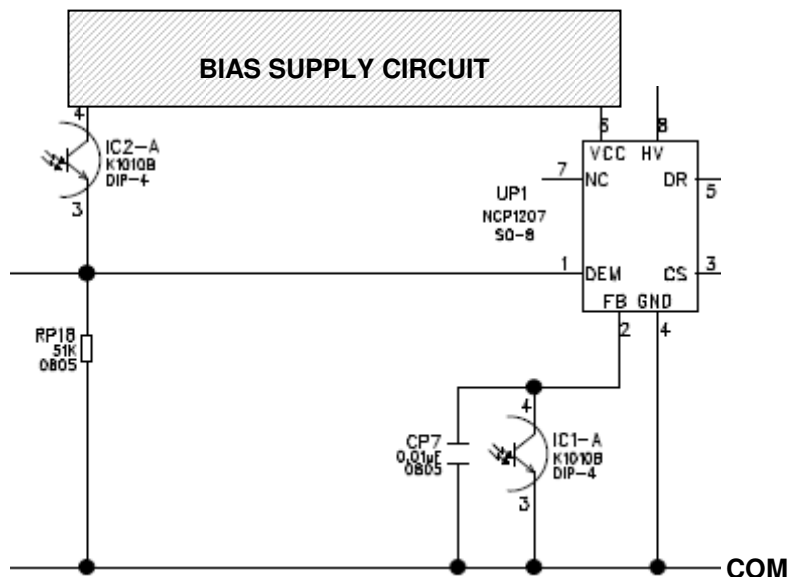

Fig. 2 – Bias/Control IC Circuit